

The documentation and process conversion measures necessary to comply with this revision shall be completed by 8 September 2001.

INCH POUND

MIL-PRF-19500/116L
8 June 2001
SUPERSEDING
MIL-PRF-19500/116K
28 February 1997

PERFORMANCE SPECIFICATION

SEMICONDUCTOR DEVICE, DIODE, SILICON, SWITCHING
TYPES 1N914, 1N914UR, 1N4148-1, 1N4148UR-1, 1N4148UB, 1N4148UB2, 1N4148UB2R, 1N4148UBCA,
1N4148UBCC, 1N4148UBCD, 1N4531, AND 1N4531UR, JAN, JANTX, JANTXV, JANHC, AND JANKC

JANS1N4148-1 (see 6.4). Device types 1N914 and 1N4531 are inactive for new design.

This specification is approved for use by all Departments and Agencies of the Department of Defense.

1. SCOPE

1.1 Scope. This specification covers the performance requirements for silicon, diffused, switching diodes. Three levels of product assurance are provided for each device type as specified in MIL-PRF-19500. Two levels of product assurance are provided for each unencapsulated device.

1.2 Physical dimensions. See figures 1 (similar to DO-35), 2, 3, 4, and 5.

1.3 Maximum ratings.

Type	V _(BR)	V _{RWM}	I _o T _A = 25°C	I _{FSM} t _p = 1/120 s	T _{STG}	T _{op}	Z _{θJX}	R _{θJL}	R _{θJC}
	V _{dc}	V (pk)	mA	A (pk)	°C	°C	°C/W	°C/W	°C/W
1N914, UR	100	75	75 (1)	1	-65 to +200	-65 to +175	70	250 (leaded) 100(UR)	N/A
1N4531, UR	100	75	125 (2)	1	-65 to +200	-65 to +175	70		N/A
1N4148-1, UR-1	100	75	200 (3)	2	-65 to +200	-65 to +200	70		N/A
1N4148UB, 1N4148UB2, 1N4148UB2R, 1N4148UBCA, 1N4148UBCC, 1N4148UBCD,	100	75	200 (3)	2	-65 to +200	-65 to +200	70		150

- (1) Derate at 0.5 mA/°C above T_A = 25°C.
- (2) Derate at 0.83 mA/°C above T_A = 25°C.
- (3) Derate at 1.14 mA/°C above T_A = 25°C.

Beneficial comments (recommendations, additions, deletions) and any pertinent data which may be of use in improving this document should be addressed to: Defense Supply Center, Columbus, ATTN: DSCC-VAC, P.O. Box 3990, Columbus, OH 43216-5000, by using the Standardization Document Improvement Proposal (DD Form 1426) appearing at the end of this document or by letter.

MIL-PRF-19500/116L

1.4 Primary electrical characteristics at $T_A = +25^\circ\text{C}$, unless otherwise indicated.

Type (1)	V_{F1}		V_{F2}		I_{R1} at $V_R = 20 \text{ V dc}$	I_{R2} at $V_R = 75 \text{ V dc}$
	I_F mA dc	V dc	I_F mA dc	V dc	nA dc	$\mu\text{A dc}$
1N914	10	0.8	50	1.2	25	0.5
1N4148-1	10	0.8	100	1.2	25	0.5
1N4531	10	0.8	100	1.2	25	0.5

Type (1)	I_{R3} at $V_R = 20 \text{ V dc}$ $T_A = 150^\circ\text{C}$	I_{R4} at $V_R = 75 \text{ V dc}$ $T_A = 150^\circ\text{C}$	t_{fr} at $V_{fr} = 5.0 \text{ V dc (pk)}$ and $I_F = 50 \text{ mA dc}$	t_{rr}
	$\mu\text{A dc}$	$\mu\text{A dc}$	ns	ns
1N914	35	75	20	5
1N4148-1	35	75	20	5
1N4531	35	75	20	5

(1) Electrical characteristics for surface mount devices are equivalent to the corresponding non-surface mount devices unless otherwise noted.

2. APPLICABLE DOCUMENTS

2.1 General. The documents listed in this section are specified in sections 3 and 4 of this specification. This section does not include documents cited in other sections of this specification or recommended for additional information or as examples. While every effort has been made to ensure the completeness of this list, document users are cautioned that they must meet all specified requirements documents cited in sections 3 and 4 of this specification, whether or not they are listed.

2.2 Government documents.

2.2.1 Specifications, standards, and handbooks. The following specifications, standards, and handbooks form a part of this document to the extent specified herein. Unless otherwise specified, the issues of these documents are those listed in the issue of the Department of Defense Index of Specifications and Standards (DoDISS) and supplement thereto, cited in the solicitation (see 6.2).

SPECIFICATION

DEPARTMENT OF DEFENSE

MIL-PRF-19500 - Semiconductor Devices, General Specification for.

STANDARD

DEPARTMENT OF DEFENSE

MIL-STD-750 - Test Methods for Semiconductor Devices.

(Unless otherwise indicated, copies of the above specifications, standards, and handbooks are available from the Document Automation and Production Services (DAPS), Building 4D (DPM-DODSSP), 700 Robbins Avenue, Philadelphia, PA 19111-5094.)

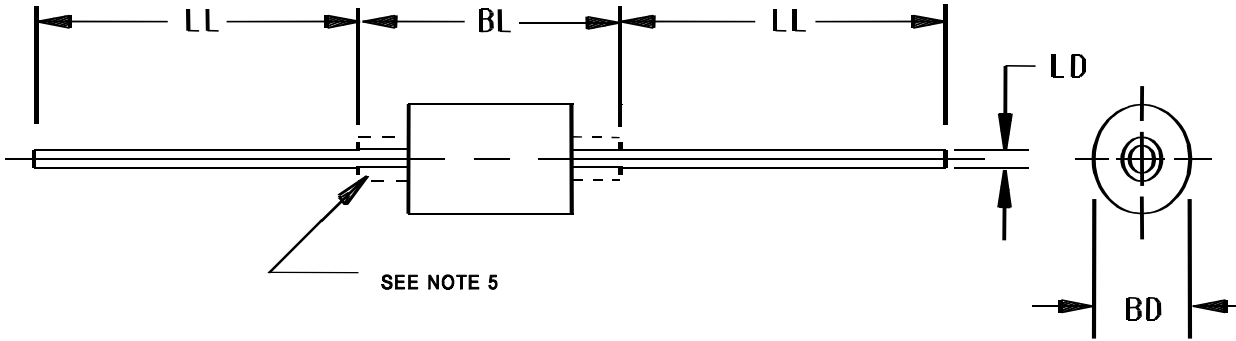

Types	Dimensions					Notes 1, 2
	Ltr	Inches		Millimeters		
		Min	Max	Min	Max	
1N4148-1 1N914	BL	.140	.180	3.56	4.57	3
	BD	.056	.075	1.42	1.90	4
	LL	1.000	1.500	25.40	38.10	
	LD	.018	.022	0.46	0.56	5
1N4531	BL	.080	.120	2.03	3.05	
	BD	.050	.075	1.27	1.90	4
	LL	1.000	1.500	25.40	38.10	
	LD	.018	.022	0.46	0.56	5

NOTES:

1. Dimensions are in inches.
2. Metric equivalents are given for general information only.
3. Ferrule is optional on types 1N4148-1 and 1N4531 for dimension BL.
4. The minimum dimension of BD shall apply over at least .075 (1.90 mm) of dimension BL.
5. The specified lead diameter applies in the zone between .050 (1.27 mm) for 1N914, and 1N4148-1, and .010 (0.25mm) for 1N4531 from the diode body to the end of the lead. Outside of this zone the lead shall not exceed BD.

FIGURE 1. Semiconductor device, diode, types 1N914, 1N4148-1, and 1N4531.

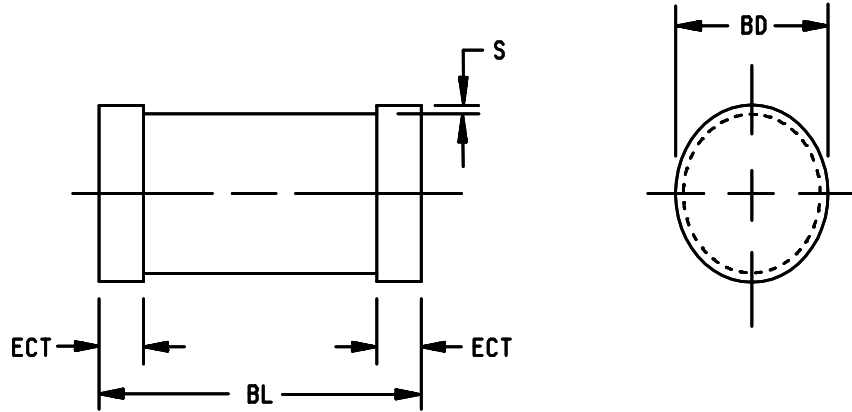

Symbol	Dimensions			
	Inches		Millimeters	
	Min	Max	Min	Max
BD	.063	.067	1.60	1.70
ECT	.016	.022	0.41	0.55
BL	.130	.146	3.30	3.70
S	.001 min		0.03 min	

NOTES:

1. Dimensions are in inches.
2. Metric equivalents are given for general information only.

FIGURE 2. Physical dimensions 1N914UR, 1N4148UR-1, AND 1N4531UR.

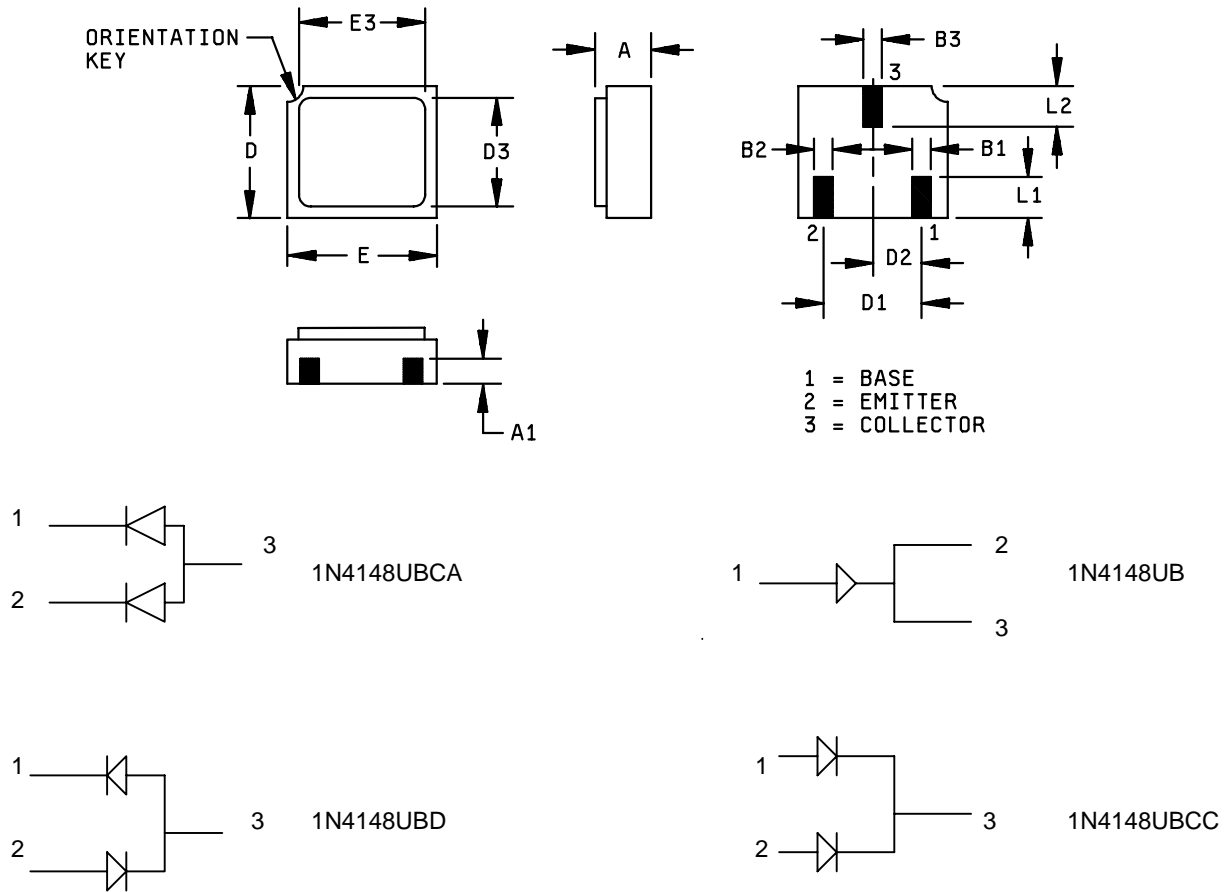

Symbol	Dimensions								
	Inches		Millimeters		Symbol	Inches		Millimeters	
	Min	Max	Min	Max		Min	Max	Min	Max
A	0.046	0.056	0.97	1.42	D1	0.071	0.078	1.81	2.01
A1	0.017	0.023	0.43	0.58	D2				
B1	0.016	0.024	0.41	0.61	D3				
B2	0.016	0.024	0.41	0.61	E	0.115	0.125	2.82	3.18
B3	0.016	0.024	0.41	0.61	E3	- - -		- - -	
D	0.085	0.105	2.41	2.67	L1	0.022	0.038	0.56	0.96
					L2	0.024	0.036	0.61	0.81

NOTES:

1. Dimensions are in inches.
2. Metric equivalents are given for general information only.
3. Ceramic package only.

FIGURE 3. Physical dimensions, surface mount (UB versions).

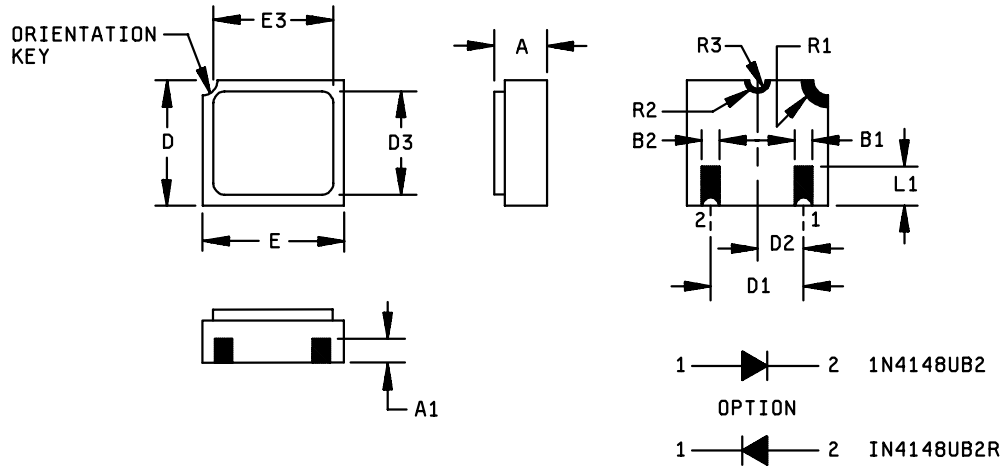

Symbol	Dimensions				Note
	Inches		Millimeters		
	Min	Max	Min	Max	
A	0.046	0.056	0.97	1.42	
A1	0.017	0.035	0.43	0.89	
B1	0.016	0.024	0.41	0.61	Typ
B2	0.016	0.024	0.41	0.61	Typ
R2	0.012		0.3		Typ
D	0.085	0.108	2.41	2.74	
D1	0.071	0.078	1.81	2.01	
D2	0.035	0.039	0.89	0.99	
D3	0.085	0.108	2.41	2.74	
E	0.115	0.128	2.82	3.25	
E3	---	0.128	---	3.25	
L1	0.022	0.038	0.56	0.96	
R3	0.008R		0.2R		
R1	0.022R		0.55R		

NOTES:

1. Dimensions are in inches.
2. Metric equivalents are given for general information only.

FIGURE 4. Physical dimensions, surface mount (2 pin UB version).

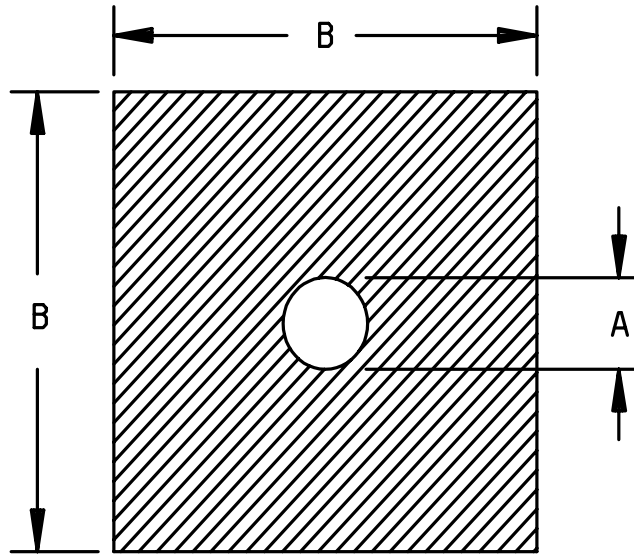

Ltr	Dimensions			
	Inches		Millimeters	
	Min	Max	Min	Max
A	.0059	.0061	.150	.155
B	.0130	.0170	.330	.430

NOTES:

1. Dimensions are in inches.
2. Metric equivalents are given for general information only.
3. Element evaluation accomplished utilizing TO-5 package.
4. The physical characteristics of the die are:

Metallization:

Top (anode): Al.

Back (cathode): Au.

Al thickness: 25,000 Å minimum.

Gold thickness: 4,000 Å minimum.

Chip thickness: .010 inches (.25 mm) ±.002 inches (.05 mm).

FIGURE 5. Physical dimensions, JANHCA and JANKCA die.

2.3 Order of precedence. In the event of a conflict between the text of this document and the references cited herein the text of this document takes precedence. Nothing in this document, however, supersedes applicable laws and regulations unless a specific exemption has been obtained.

3. REQUIREMENTS

3.1 General. The requirements for acquiring the product described herein shall consist of this document and MIL-PRF-19500.

3.2 Qualification. Devices furnished under this specification shall be products that are manufactured by a manufacturer authorized by the qualifying activity for listing on the applicable qualified manufacturer's list (QML) before contract award (see 4.2 and 6.3).

3.3 Abbreviations, symbols, and definitions. Abbreviations, symbols, and definitions used herein shall be as specified in MIL-PRF-19500 and as follows.

V_{fr}	Forward recovery voltage. Specified maximum forward voltage used to determine forward recovery time.
LS	Lead spacing distance between device body and electrical/mechanical contact on lead.
UB	Hermetic unleaded 3 terminal (LCC, Leadless Chip Carrier) package type.
UR	Unleaded round package type designation.

3.4 Interface and physical dimensions. Interface and physical dimensions shall be as specified in MIL-PRF-19500, and on figures 1, 2, 3, 4, and 5 herein.

3.4.1 Lead finish. Lead finish shall be solderable in accordance with MIL-PRF-19500, MIL-STD-750, and herein. Where a choice of lead finish is desired, it shall be specified in the acquisition document (see 6.2).

3.4.2 Diode construction. All devices (except UB version) shall be metallurgically bonded double plug construction in accordance with the requirements of category I, II, or III (see MIL-PRF-19500). The UB package shall be wire bonded, eutectically mounted devices.

3.5 Electrical performance characteristics. Unless otherwise specified herein, the electrical performance characteristics are as specified in 1.3, 1.4, and table I.

3.6 Electrical test requirements. The electrical test requirements shall be the subgroups specified in 4.4.2 and 4.4.3 herein.

3.7 Marking. Marking shall be in accordance with MIL-PRF-19500. At the option of the manufacturer, marking may be omitted from the body, but shall be retained on the initial container.

3.7.1 UR devices. "UR" devices shall be marked with a cathode band only. Initial container package marking shall be in accordance with MIL-PRF-19500.

3.7.2 UB devices. The part number may be reduced to J4148, JX4148, or JV4148. Manufacturers identification and date code shall be marked on the devices.

3.7.3 UBR devices. The part number may be reduced to J4148, JX4148, or JV4148. Manufacturers identification and date code shall be marked on the devices.

3.8 Polarity. The polarity shall be indicated with a contrasting color band to denote the cathode end. No color coding will be permitted. UB packages do not require polarity marking.

3.9 Workmanship. Semiconductor devices shall be processed in such a manner as to be uniform in quality and shall be free from other defects that will affect life, serviceability, or appearance.

4. VERIFICATION

4.1 Classification of inspections. The inspection requirements specified herein are classified as follows:

- a. Qualification inspection (see 4.2).
- b. Screening (see 4.3).
- c. Conformance inspection (see 4.4).

4.2 Qualification inspection. Qualification inspection shall be in accordance with MIL-PRF-19500 and as specified herein.

4.2.1 Group E inspection. Group E inspection shall be in accordance with MIL-PRF-19500 and table II herein.

4.3 Screening (JAN, JANTX, and JANTXV levels only). Screening shall be in accordance with table IV of MIL-PRF-19500 and as specified herein. The following measurements shall be made in accordance with table I herein. Devices that exceed the limits of table I herein shall not be acceptable.

Screen (see table IV of MIL-PRF-19500)	Measurement	
	JAN level	JANTX and JANTXV levels
3a	Temperature cycling in accordance with MIL-PRF-19500 TX level.	Temperature cycling
3c (1)	Thermal impedance (see 4.5.5)	Thermal impedance (see 4.5.5)
9	Not applicable	Not applicable
10 (2)	Not applicable	Method 1038, condition A, t = 48 hours
11	Not applicable	I_{R1} and V_{F1}
12	Not applicable	See 4.3.1, t = 48 hours
13	Not applicable	(3) Subgroup 2 of table I herein; $\Delta I_{R1} = 100$ percent of initial reading or 15 nA, whichever is greater; $\Delta V_{F1} = 25$ mV dc. PDA = 10 percent

- (1) Thermal impedance shall be performed any time after sealing provided temperature cycling is performed in accordance with MIL-PRF-19500, screen 3 prior to this thermal test.
- (2) Test within 24 hours after removal from test.
- (3) When thermal impedance is performed prior to screen 13, it is not required to be repeated in screen 13.

4.3.1 Burn-in test conditions. Burn-in conditions are as follows:

Type	$T_A +30^\circ\text{C} \pm 5^\circ\text{C}$ $V_{RWM} = 75$ V (pk) $f = 50 - 60$ Hz	$T_A = +30^\circ\text{C} \pm 5^\circ\text{C}$
1N914, 1N914UR	$I_O = 75$ mA	$I_F = 150$ mA min
1N4531, 1N4531UR	$I_O = 125$ mA	$I_F = 175$ mA min
1N4148-1, 1N4148UR-1, 1N4148UB, 1N4148UB2, 1N4148UBR2	$I_O = 200$ mA	$I_F = 200$ mA min

4.4 Conformance inspection. Conformance inspection shall be in accordance with MIL-PRF-19500 and as specified herein.

4.4.1 Group A inspection. Group A inspection shall be conducted in accordance with MIL-PRF-19500 and table I herein. Electrical measurements (end-points) shall be in accordance with Table I, group A, subgroup 2 herein.

4.4.2 Group B inspection. Group B inspection shall be conducted in accordance with the conditions specified for subgroup testing in table VIb (JANTX and JANTXV) of MIL-PRF-19500 and as specified herein. Electrical measurements (end-points) shall be in accordance with Table I, group A, subgroup 2 herein except for the thermal impedance test.

4.4.2.1 Group B inspection, table VIb (JANTX, JANTXV) of MIL-PRF-19500.

<u>Subgroup</u>	<u>Method</u>	<u>Conditions</u>
B2	2005	$I_F = 100$ mA, axial tensile stress = 8 lbs, $T_A = +150^\circ\text{C}$; (not applicable to UR or UB package). (This test shall be performed as the first test of subgroup 2).
B3	1027	$T_A = +30^\circ\text{C} \pm 5^\circ\text{C}$, $V_{RWM} = 75$ V(pk), $f = 50$ -60 Hz (see 4.5.1); 1N914: $I_O = 5$ mA, 1N4531: $I_O = 125$ mA, 1N4148-1: $I_O = 200$ mA.
B4	2075	See 4.5.4 herein.
B5	3101 or 4081	$R_{\theta JL} = 250^\circ\text{C/W}$, .375 inch (9.52 mm) lead length (non-surface mount). $R_{\theta JL} = 100^\circ\text{C/W}$ (UR), $R_{\theta JC} = 150^\circ\text{C/W}$ (UB).

4.4.3 Group C inspection. Group C inspection shall be conducted in accordance with the conditions specified for subgroup testing in table VII of MIL-PRF-19500, and as follows. Electrical measurements (end-points) shall be in accordance with Table I, group A, subgroup 2 herein except for the thermal impedance test.

<u>Subgroup</u>	<u>Method</u>	<u>Conditions</u>
C2	1056	100 cycles.
C2	2036	Tension: Test condition A, $t = 15$ seconds, weight = 10 pounds. Lead fatigue: Test condition E. Terminal strength and lead fatigue not applicable to UB or UR devices.
C6	1026	$T_A = +30^\circ\text{C} \pm 5^\circ\text{C}$, $V_{RWM} = 75$ V(pk), $f = 50$ -60 Hz (see 4.5.1), for: 1N914 $I_O = 75$ mA. 1N4531 $I_O = 125$ mA. 1N4148-1 $I_O = 200$ mA.

4.5 Methods of inspection. Methods of inspection shall be as specified in the appropriate tables and as follows.

4.5.1 Pulse measurements. Conditions for pulse measurements shall be specified in section 4 of MIL-STD-750.

4.5.2 Life tests. AC tests shall be conducted with a half-sine wave of the peak voltage specified herein impressed across the diode in the reverse direction, followed by a half-sine waveform of the average rectified current specified herein. The forward conduction angle of the rectified current shall be not greater than 180 degree nor less than 150 degree.

4.5.3 Forward recovery voltage and time. Forward recovery time shall be measured as the time interval between zero time and the point where the pulse has decreased to 110 percent of the steady-state value of V_F when $I_F = 50$ mA dc. The maximum rise time of the response detector shall be 1 ns.

4.5.4 Decap internal visual scribe and break (not applicable to UB package). Scratch glass at cavity area with diamond scribe. Carefully snap open. Using 30X magnification examine the area where die was in contact with the plugs, verify footprint for minimum of 15 percent metallurgical bonding area. In addition, a cross sectional view may be used to verify consistency of construction. A cross sectional view shall be used exclusively for construction verification and shall not be used to verify bond integrity. The UB package shall employ the manufacturers' normal delidding procedures.

4.5.5 Thermal impedance ($Z_{\theta JX}$ measurements). Thermal impedance measurements shall be in accordance method 3101 MIL-STD-750, and as follows.

- a. $I_H = 300$ mA to 500 mA.
- b. $t_H = 10$ ms.
- c. $I_M = 1$ mA to 10 mA.
- d. $t_{MD} = 70$ μ s maximum.

The maximum limit for $Z_{\theta JX}$ under these test conditions is $Z_{\theta JX} = 70^\circ\text{C/W}$.

4.5.5.1 For initial qualification or requalification. Read and record data ($Z_{\theta JX}$) shall be supplied to the qualifying activity on one lot (random sample of 500 devices minimum) prior to shipment. Twenty two samples shall be serialized and provided to the qualifying activity for test correlation.

4.5.6 Thermal resistance. Thermal resistance measurement shall be in accordance with method 3101 MIL-STD-750, or method 4081 of MIL-STD-750. Forced moving air or draft shall not be permitted across the device during test. The maximum limit for $R_{\theta JL}$ under these test conditions shall be as shown in group B of 4.4.2.1 and group E of table II. The following conditions shall apply when using method 3101:

- a. I_H ----- 75 mA to 300 mA.
- b. t_H ----- 25 seconds minimum.
- c. I_M ----- 1 mA to 10 mA.
- d. t_{MD} ----- 70 μ s maximum.

4.5.6.1 Lead spacing for leaded devices:

LS = Lead spacing = .375 inch (9.53 mm) as defined on figure 6.

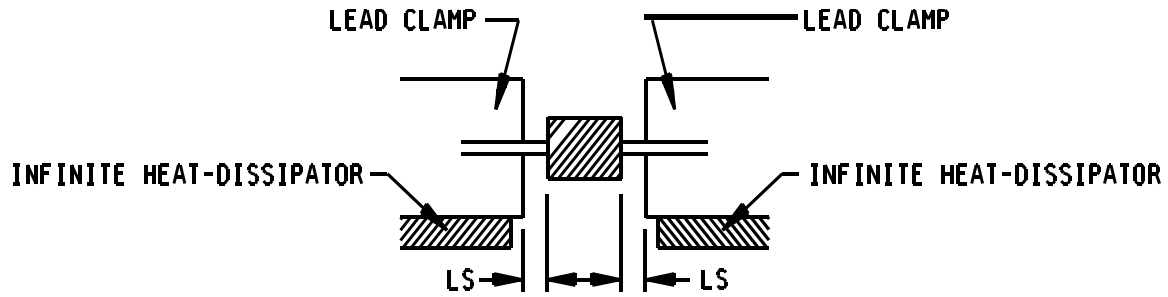

FIGURE 6. Mounting conditions.

4.5.6.2 Temperature reference (T_r) unleaded devices (UB, UR suffix). The temperature reference point shall be the hottest portion of the external surface. As an alternate, the temperature of a stream of liquid used to cool the device during the test may be used as the temperature reference point.

MIL-PRF-19500/116L

TABLE I. Group A inspection.

Inspection 1/	MIL-STD-750		Symbol	Limits		Unit
	Method	Conditions		Min	Max	
<u>Subgroup 1</u>						
Visual and mechanical inspection	2071					
<u>Subgroup 2</u>						
Thermal impedance	3101	See 4.5.5	$Z_{\theta JX}$		70	°C/W
Forward voltage	4011	$I_F = 10 \text{ mA dc}$	V_{F1}		0.8	V dc
Breakdown voltage	4021	$I_R = 100 \mu\text{A dc}$	V_{BR1}	100		V dc
Reverse current	4016	DC method $V_R = 20 \text{ V dc}$	I_{R1}			
1N914				25		nA dc
1N4531				25		nA dc
1N4148-1				25		nA dc
Reverse current	4016	DC method $V_R = 75 \text{ V dc}$	I_{R2}	500		nA dc
Forward voltage	4011		V_{F2}			
		$I_F = 50 \text{ mA dc}$		1.2		V dc
		$I_F = 100 \text{ mA dc}$		1.2		V dc
		$I_F = 100 \text{ mA dc}$		1.2		V dc
<u>Subgroup 3</u>						
High temperature operation:		$T_A = +150^\circ\text{C}$				
Reverse current	4016	DC method $V_R = 20 \text{ V dc}$	I_{R3}		35	$\mu\text{A dc}$
1N914						
1N4531						
1N4148-1						
Reverse current	4016	DC method $V_R = 75 \text{ V dc}$	I_{R4}			
1N914					75	$\mu\text{A dc}$
1N4531					75	$\mu\text{A dc}$
1N4148-1					75	$\mu\text{A dc}$
Forward voltage	4011	$I_F = 10 \text{ mA dc}$	V_{F3}			
1N914					0.8	V dc
1N4531					0.8	V dc
1N4148-1					0.8	V dc

See footnote at end of table.

TABLE I. Group A inspection - Continued.

Inspection 1/	MIL-STD-750		Symbol	Limits		Unit
	Method	Conditions		Min	Max	
<u>Subgroup 3 - Continued</u>						
Low temperature operation:		$T_A = -55^\circ\text{C}$				
Forward voltage	4011		V_{F4}			
1N914		$I_F = 50 \text{ mA dc}$			1.3	V dc
1N4531		$I_F = 100 \text{ mA dc}$			1.3	V dc
1N4148-1		$I_F = 100 \text{ mA dc}$			1.3	V dc
<u>Subgroup 4</u>						
Junction capacitance	4001	$V_R = 0 \text{ V dc}, f = 1 \text{ MHz},$ $V_{\text{sig}} = 50 \text{ mV}_{\text{p-p}}$ maximum	C_1			
1N914					4.0	pF
1N4531					4.0	pF
1N4148-1					4.0	pF
Junction capacitance	4001	$V_R = 1.5 \text{ V dc}, f = 1 \text{ MHz},$ $V_{\text{sig}} = 50 \text{ mV}_{\text{p-p}}$ maximum	C_2		2.8	pF
Reverse recovery time	4031	Condition A $C \geq 1 \text{ nF}, I_F = I_R = 10 \text{ mA dc}, R_L = 100\Omega \pm 5\%$ $I_{R(\text{REC})} = 1.0 \text{ mA dc}, R \geq 1000\Omega.$	t_{rr}		5	ns
1N914						
1N4531						
1N4148-1						
<u>Subgroup 5</u>						
Not applicable						

See footnote at end of table.

TABLE I. Group A inspection - Continued.

Inspection <u>1/</u>	MIL-STD-750		Symbol	Limits		Unit
	Method	Conditions		Min	Max	
<u>Subgroup 6</u>						
Surge current	4066	Condition A (sine wave) $i_{f(\text{surge})} = 1 \text{ A (pk)}$ for 1N914 and 1N4531 $i_{f(\text{surge})} = 2 \text{ A (pk)}$ for 1N4148-1, UR and 1N4148UB, $I_O = \text{maximum rated dc current} = 0$ $V_{RM} = 0$ 10 surges, 8.3 ms width each, one surge per minute, $T_A = +25^\circ\text{C}$ or Condition B (square wave) $I_{F(\text{surge})} = 0.704 \text{ A (pk)}$ for 1N914, 1N4531, and 1N4148UB $I_{F(\text{surge})} = 1.41 \text{ A (pk)}$ for 1N4148-1 $t_p = 8.3 \text{ ms}$ $n = 10$ $d.f. = 0.0055\%$ $T_A = 25^\circ\text{C}$				
Electrical measurements		See table I, subgroup 2				
<u>Subgroup 7</u>						
Forward recovery voltage and time	4026	$I_F = 50 \text{ mA dc}$ (see 4.5.2)	V_{fr} t_{fr}	5.0 20	$V \text{ (pk)}$ ns	

1/ For sampling plan, see MIL-PRF-19500.

MIL-PRF-19500/116L

TABLE II. Group E inspection (all quality levels) for qualification only.

Inspection 1/	MIL-STD-750		Sampling plan
	Method	Conditions	
<u>Subgroup 1</u>			45 devices c = 0
Thermal shock (glass strain)	1056	1,000 cycles	
Electrical measurements		See table I, subgroup 2	
<u>Subgroup 2</u>			45 devices c = 0
Intermittent operating life	1037	10,000 cycles	
Electrical measurements		See table I, subgroup 2	
<u>Subgroup 3</u>			
Not applicable			
<u>Subgroup 4</u>			22 devices c = 0
Thermal resistance surface mount	3101 or 4081	$R_{\theta JEC} = 100^{\circ}\text{C/W}$ (maximum) at zero lead length (for UR), $R_{\theta JEC} = 150^{\circ}\text{C/W}$ (maximum) for UB. (see 4.5.6), $+25^{\circ}\text{C} \leq T_R \leq +35^{\circ}\text{C}$	
Thermal resistance leaded devices	3101 or 4081	$R_{\theta JEC} = 250^{\circ}\text{C/W}$ (maximum) $+25^{\circ}\text{C} \leq T_R \leq +35^{\circ}\text{C}$, (see 4.5.6) $t_H \geq 25\text{s}$ in still air.	
<u>Subgroup 5</u>			22 devices c = 0
Monitored mission temperature cycling	1055	Not required for UB suffix devices.	
Electrical measurements		See table I, subgroup 2	

5. PACKAGING

5.1 Packaging. For acquisition purposes, the packaging requirements shall be as specified in the contract or order (see 6.2). When actual packaging of materiel is to be performed by DoD personnel, these personnel need to contact the responsible packaging activity to ascertain requisite packaging requirements. Packaging requirements are maintained by the Inventory Control Point's packaging activity within the Military Department or Defense Agency, or within the Military Department's System Command. Packaging data retrieval is available from the managing Military Department's or Defense Agency's automated packaging files, CD-ROM products, or by contacting the responsible packaging activity.

6. NOTES

(This section contains information of a general or explanatory nature that may be helpful, but is not mandatory.)

6.1 Intended use. The notes specified in MIL-PRF-19500 are applicable to this specification.

6.2 Acquisition requirements. Acquisition documents must specify the following:

- a. Title, number, and date of this specification.
- b. Issue of DoDISS to be cited in the solicitation and, if required, the specific issue of individual documents referenced (see 2.2.1).
- c. Packaging requirements (see 5.1).
- d. Lead finish (see 3.4.1).
- e. Type designation and product assurance level.

6.3 Qualification. With respect to products requiring qualification, awards will be made only for products which are, at the time of award of contract, qualified for inclusion in Qualified Manufacturers' List (QML) whether or not such products have actually been so listed by that date. The attention of the contractors is called to these requirements, and manufacturers are urged to arrange to have the products that they propose to offer to the Federal Government tested for qualification in order that they may be eligible to be awarded contracts or orders for the products covered by this specification. Information pertaining to qualification of products may be obtained from Defense Supply Center, Columbus, ATTN: DSCC/VQE, P.O. Box 3990, Columbus, OH 43216-5000.

6.4 Cross reference substitution information. The JANS version of 1N6638, 1N6642, or 1N6643 (MIL-S-19500/578) is preferred in lieu of the JANS1N4148-1. The JANS 1N6638 or 1N6642 is substitutable for the JANS 1N4148-1 and shall be used in lieu of the JANS1N4148-1. A PIN for PIN replacement table follows, and these devices are directly interchangeable.

JANS Non-preferred PIN	JANS superseded PIN
1N4148-1	1N6638 1N6642

6.5 Suppliers of JANHC and JANKC die. The qualified JANHC and JANKC suppliers with the applicable letter version (example JANHCA1N4148) will be identified on the QPL.

JANC ordering information		
PIN	Manufacturer	
	55801	
1N4148-1 1N4148-1	JANHCA1N4148 JANKCA1N4148	

6.6 Changes from previous issue. Marginal notations are not used in this revision to identify changes with respect to the previous issue due to the extent of the changes.

Custodians:
 Army - CR
 Navy - NW
 Air Force - 11
 DLA - CC

Preparing activity
 DLA - CC

(Project 5961-2422)

Review activities:
 Army - AR, MI, SM
 Navy - AS, CG, MC
 Air Force - 19, 99

STANDARDIZATION DOCUMENT IMPROVEMENT PROPOSAL

INSTRUCTIONS

1. The preparing activity must complete blocks 1, 2, 3, and 8. In block 1, both the document number and revision letter should be given.
2. The submitter of this form must complete blocks 4, 5, 6, and 7.
3. The preparing activity must provide a reply within 30 days from receipt of the form.

NOTE: This form may not be used to request copies of documents, nor to request waivers, or clarification of requirements on current contracts. Comments submitted on this form do not constitute or imply authorization to waive any portion of the referenced document(s) or to amend contractual requirements.

I RECOMMEND A CHANGE:	1. DOCUMENT NUMBER MIL-PRF-19500/116K	2. DOCUMENT DATE 13 July 2001
------------------------------	--	----------------------------------

3. **DOCUMENT TITLE** SEMICONDUCTOR DEVICE, DIODE, SILICON, SWITCHING TYPES 1N914, 1N914UR, 1N4148-1, 1N4148UR-1, 1N4148UB, 1N4148UB2, 1N4148UBR2, 1N4531, AND 1N4531UR, JAN, JANTX, JANTXV, JANHC, AND JANKC

4. **NATURE OF CHANGE** (Identify paragraph number and include proposed rewrite, if possible. Attach extra sheets as needed.)

5. **REASON FOR RECOMMENDATION**

6. **SUBMITTER**

a. NAME (Last, First, Middle initial)	b. ORGANIZATION	
c. ADDRESS (Include Zip Code)	d. TELEPHONE (Include Area Code) COMMERCIAL DSN FAX EMAIL	7. DATE SUBMITTED

8. **PREPARING ACTIVITY**

a. Point of Contact Alan Barone	b. TELEPHONE Commercial DSN FAX EMAIL 614-692-0510 850-0510 614-692-6939 alan.barone@dsccl.dla.mil		
c. ADDRESS Defense Supply Center, Columbus ATTN: DSCC-VAC P.O. Box 3990 Columbus, OH 43216-5000	IF YOU DO NOT RECEIVE A REPLY WITHIN 45 DAYS, CONTACT: Defense Standardization Program Office (DLSC-LM) 8725 John J. Kingman, Suite 2533 Fort Belvoir, VA 22060-6221 Telephone (703) 767-6888 DSN 427-6888		